

FOCUS ON YOUR TASK

MADE
IN
GERMANY

VUMAN^{E3+} dition



viZaar[®]
industrial imaging AG

DOWN TO Ø **6** MM UP TO 30 M PROBE LENGTH

The Definition of Long Range

**THE LARGEST
TOUCHSCREEN**
TRANSREFLECTIVE AND
OPERABLE WITH GLOVES

**MAXIMUM
FLEXIBILITY**
MULTI POSITION VUSCREEN
FOR OPTIMUM ERGONOMICS

**THE SHARPEST
IMAGE**
THANKS TO OUR PATENTED
REMOTE FOCUS TECHNOLOGY

**THE BRIGHTEST
DUAL LED LIGHTS**
WITH LONG TIME WARRANTY

**THE MOST ADAPTABLE
VIDEO IN/OUT**
HDMI AND ANALOGUE

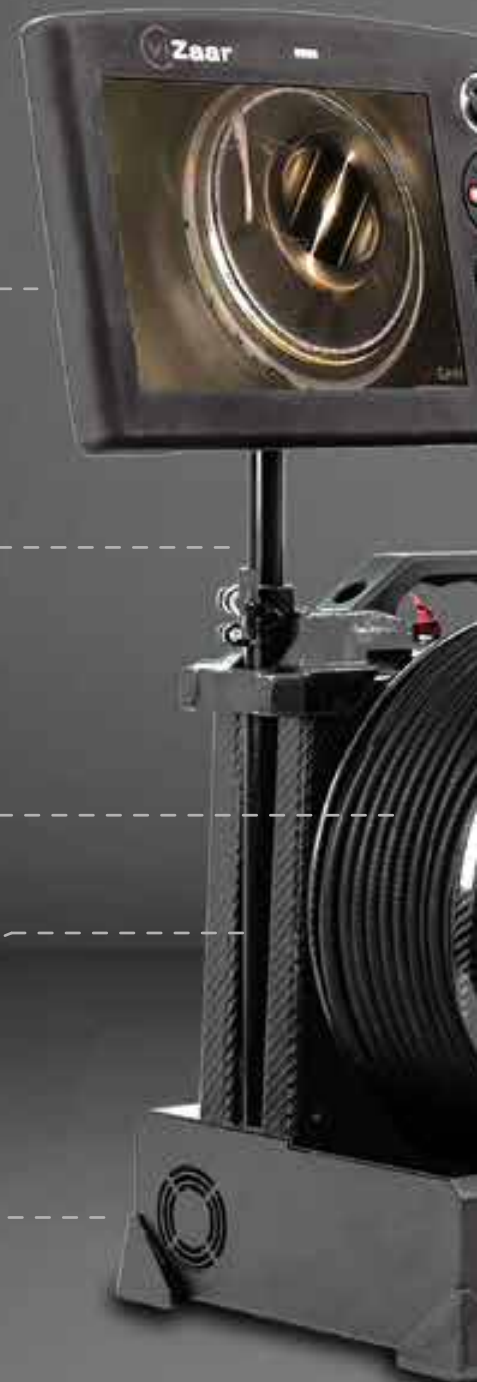

VUMAN® *E3⁺* dition

THE MOST PRECISE ARTICULATION

JOYSTICK CONTROL
ABSOLUTE AND RELATIVE ARTICULATION

THE MOST INTUITIVE OPERATION

SLIDEBARS FOR
REMOTE FOCUS AND ILLUMINATION

THE SAFEST DEPLOYMENT DRUM

WITH HANDLE FOR EASY STOWING
OF THE PROBE

THE LIGHTEST CARBON FIBER HOUSING

HIGH QUALITY AND ROBUST WITH
LIFETIME WARRANTY

THE UNIQUE MICRO COMPRESSOR

MAINTENANCE - FREE AND DIRECTLY
INTEGRATED IN THE SYSTEM

HIGH PERFORMANCE NiMH - BATTERY

1 - 2 HOURS OPERATION, INCL. MICRO COMPRESSOR
WITHOUT EXTERNAL POWER SUPPLY



VUM

UNIQUE FEATURES

SUCCESS IN EVERY INSPECTION





LARGEST TOUCHSCREEN

Unique and portable LCD control unit with 10.4" touchscreen. Control your probe and all features via touchscreen and direct access buttons. Also usable with protective gloves.



HIGH POWER DUAL LED

Each LED can be independently controlled to allow for increased contrast or avoid any reflection issues. Integrated 'boost' function and extended shutter time for clear visualisation in large cavities.



MEDIA AND DATA CAPTURE

Record high resolution videos and images with personalized text entries, reference charts or customer logos. Manage all inspection data in the customizable file manager and export your data to a USB drive.



X-WAY ARTICULATION

VUMAN® interchangeable video probes with unique X-WAY camera articulation in every direction for probe lengths up to 30 m.



REMOTE FOCUS

Patented remote focus technology allowing for full focal control without exchanging lenses.



BATTERY POWERED

Powerful modular NiMH battery power for maximum mobility. Charges in use if on mains power. Seamlessly switch between charging, battery mode and mains. IATA air transport compliant, non-flammable.

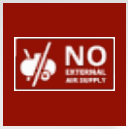

NO EXTERNAL AIR SUPPLY

Full X-WAY articulation without external air supply or cartridge due to the integrated micro compressor.



SAFE PROBE DEPLOYMENT DRUM

Avoid tripping and damage to your probe while maintaining a clean working environment. Enjoy full X-WAY probe articulation with the majority of your probe stored on the probe deployment drum.



CARBON HOUSING

Robust and durable, compact and lightweight, optimized for industrial environments.

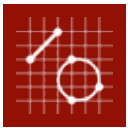

MEASUREMENT FUNCTION

E3+: Integrated measurement system for measurement of linear distance, radius, circumference and area. Limitless reference measurement.



HOT SHOP REPAIR

100 % customer commitment: Our Hot Shop service meets the demands of all our customers, even those in the most demanding industries. We also offer a spare parts service. viZaar is ISO 9001, ISO 14001 and KTA 1401 certified.



INTEGRATED SOLID STATE DRIVE

Store countless images and videos securely and safely on to the integrated 80GB solid state hard drive.



THE ULTIMATE LONG RANGE VIDEOSCOPE INSPECTION SYSTEM

PERFECT VISION FOR EVERY WORKING LENGTH

With up to 30 m long video probes, the VUMAN E3/E3+ is specifically designed for inspections that require a long range. The proprietary hybrid, high power, polymer dual LED illumination system provides class leading, homogenous illumination and excellent colour temperature. There is no need for a laser safety officer when operating the VUMAN®.

The unique patented REMOTE FOCUS system incorporated into the VUMAN® system ensures perfect documentation results without the need to withdraw the videoprobe from the application and to change lenses. This will reduce the inspection duration and user fatigue, save time and lower costs.

ONE DEVICE FOR EVERY APPLICATION

CLOSE UP TO ∞

POPULAR APPLICATIONS

Plant and pipeline constructions

- welds
- heat tinting
- corrosion, erosion
- foreign object search and retrieval (in combination with retrieval tools)

Turbines, pumps, gears, generators

- cavitation, erosion, salinisation
- surfaces, discolouration
- cracks, breakages
- corrosion
- FOSAR



RANGE OF FOCUS AND ILLUMINATION

VIZAAR REMOTE FOCUS VS STANDARD FIX FOCUS SYSTEMS

UNLIMITED

Carry out inspections in only one operation, without repeatedly inserting and retracting the probe into and from the application for the inconvenient change of optic adapters. Benefit from always having the best image quality.

Patented remote focus technology by viZaar

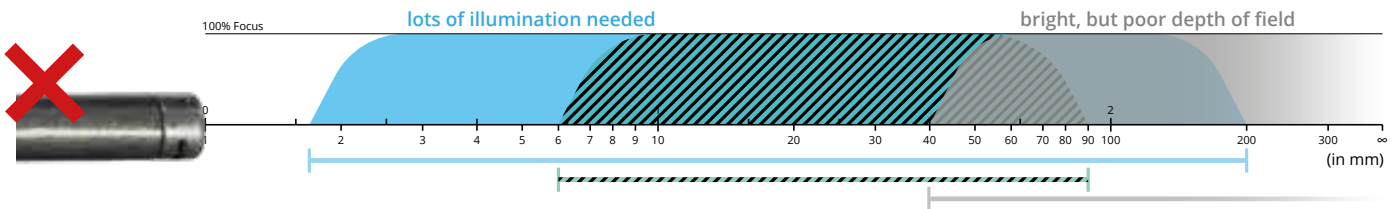
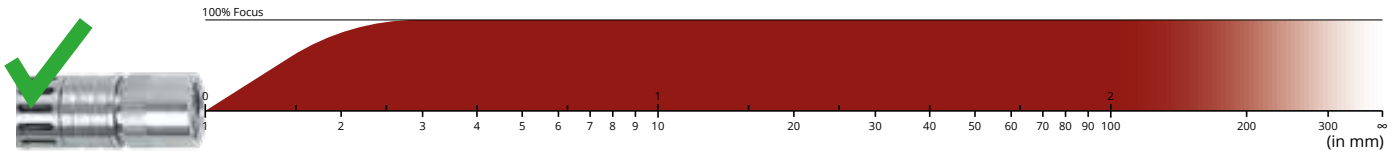

Conventional fix focus systems

LIMITED

The use of tip adapters is limiting as during the inspection, the scope may have to be withdrawn for several tip changes. Tip adaptations also absorb light and thus reduce image quality.



THE UNIQUE INTERCHANGEABLE 6 MM VIDEO PROBE

NOW FOR EVEN NARROWER TEST ENVIRONMENTS

With a diameter of only 6.1 mm and probe lengths up to 30 m, our new VUMAN 6 mm X-WAY video probe is the only one of its kind. This probe makes inspections possible which before required expensive and long downtimes.



45°

120°

120°

Optimize your inspection
with three different optional side
view and wideangle optic adapters.



VERSATILE PROBE ARTICULATION

CLASS LEADING 4-WAY ARTICULATION FOR LONG RANGE VIDEO PROBES



The pneumatic X-WAY articulation system allows for full 4 axis (up/down/left/right) articulation of all VUMAN® X-WAY probes via joystick on the VUSCREEN control unit. It is powered by an integrated, computer controlled micro-compressor, so there is no need for external air sources or gas canisters.

Discover the advantages of a highly precise camera head articulation when operating in relative articulation mode with activated freeze function. Switch to absolute articulation when you need to work fast.

The X-WAY articulation can be applied to probes of up to 30 m length. Full probe articulation is still possible when a large part of the probe remains on the deployment drum. This way, tripping can be avoided and the probe is securely stored.

CENTERING TOOLS

THE IDEAL CENTERING AID FOR EACH PROBE

Centering tools are the perfect aid for precise positioning of video probes. Keep constant distance to the tested surface and achieve optimal results, e. g. when inspecting longitudinal and orbital weld seams in tubes. Furthermore, the ideal positioning of the camera shortens the duration of your visual inspection. Also, using the right centering tools will protect your probe from residues and contamination.

• Universal centering tool: suitable for most 6 and 8 mm video probes on the market.

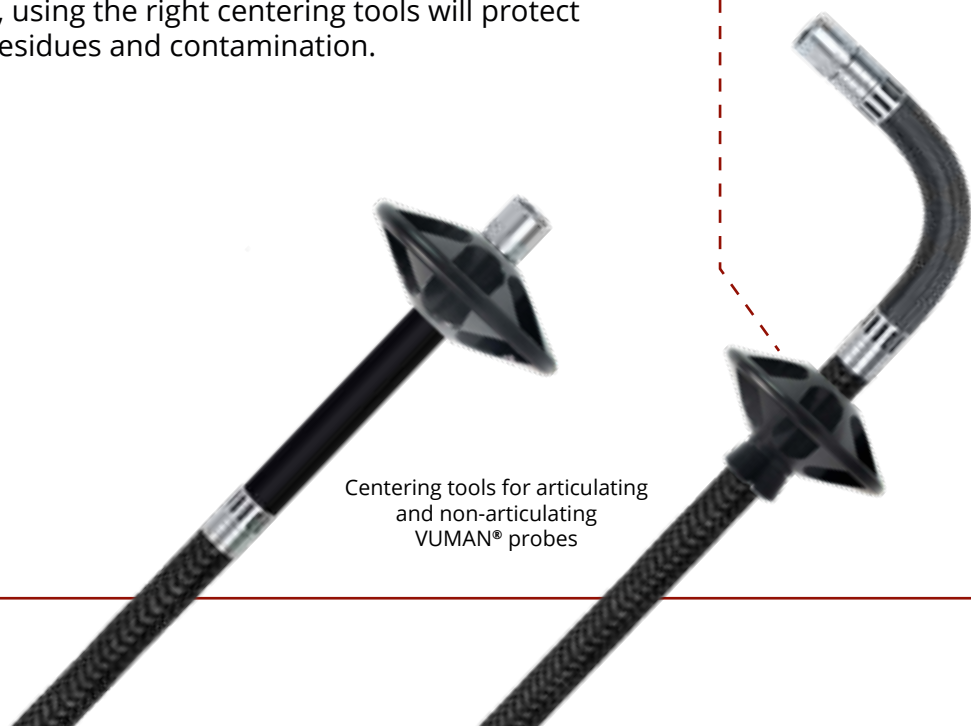

Centering tools for articulating and non-articulating VUMAN® probes

VUMAN® INTERCHANGEABLE VIDEO PROBES

A TOOL FOR EVERY TASK

If you have a long range inspection need, the VUMAN® system can now fulfil even more of your needs than before: From 6.1 mm articulating probes to 12.7 mm 360° rotating orbital inspection probes.



**THE WORLD'S SMALLEST
DIAMETER ARTICULATING
LONG RANGE PROBE!**

Our professional push rod, suitable for every VUMAN® probe!

INTERCHANGEABLE VIDEO PROBE VUMAN® 6

← reinforced →

→ flexible+ ←

INTERCHANGEABLE VIDEO PROBE VUMAN® 6 X-WAY

INTERCHANGEABLE VIDEO PROBE VUMAN® 8

INTERCHANGEABLE VIDEO PROBE VUMAN® 8 X-WAY

INTERCHANGEABLE VIDEO PROBE VUMAN® REVOLVER 12.7



Some applications require a variety of video probes with different lengths and diameters. The concept of interchangeable probes allows for a quick and simple exchange of video probes on-site, avoiding the parallel use of several endoscope systems.

In case of contamination, e. g. in chemical or nuclear industry, it also allows for the probe to be removed or disposed without having to clean or dispose of the entire system.

:: Maximum range

Interchangeable VUMAN® video probes are available in lengths from 5 m to 30 m and with optional push rods.

:: Optimally functional construction

The system was developed based on the feedback of our customers and service technicians, and optimized in the 3rd generation.

:: Ideal probe characteristics

The tungsten or polyurethane stainless steel reinforced composite construction for excellent stability, best sliding properties and torsional stiffness. Different flexibility levels for flexibility+ 6 mm probes.

:: Always in focus

The patented Remote Focus technology is offering the best resolution on the market: 30 µm at 4 mm distance without additional optic adapters.

:: Perfect for Nuclear

viZaar is KTA 1401 certified. Therefore, our VUMAN technology is compliant with all requirements for the use in nuclear power plants.

:: Optimized for your inspection

Our non-articulating video probes are designed for heavy duty tube inspections over long periods. Operated with centering devices, these video probes with their spring loaded probe tip are an economically unbeatable and robust remote visual inspection system for your tube inspection needs. X-WAY probes will help you overcome the most difficult inspections such as visual testing of turbines and pumps.

:: Endlessly rotating camera head

Revolver 12.7: patented motor-driven camera head with variable rotation speed and direction for optimal testing of inner pipe walls.

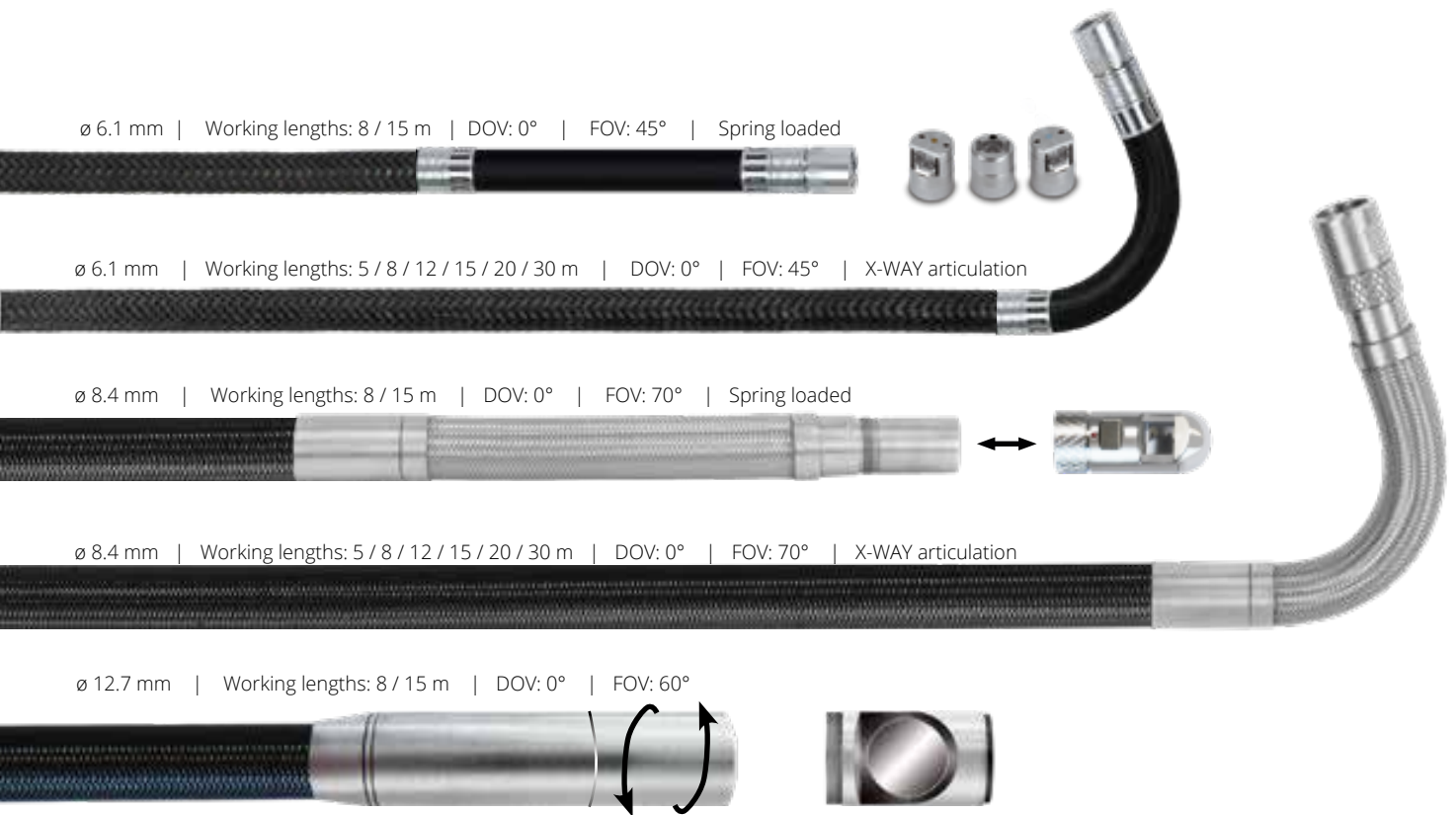

Continuously rotating head with side view adapter and variable rotation speed



USER FRIENDLY CONTROL UNIT

UNIQUE AND PORTABLE



The VUSCREEN combines PPE-compatibility, e.g. working with gloves, with an intuitive user interface and advanced software features. It offers perfect camera control via joystick in any situation and renders a crystal clear image onto the 10.4" screen.

Record images and videos in full resolution and capture snapshots for later analysis with a simple push of a button.

- 1 Carbon fiber with elastomer bumpers
- 2 Battery status LED
- 3 Intuitive joystick control
- 4 Direct access buttons
- 5 Slide bar for illumination and focus
- 6 Resistive touchscreen, operation with protective gloves possible

LITHIUM-FREE BATTERY

SAFE OPERATION AND TRANSPORTATION

Maximum mobility and flexibility is provided by the new and improved NiMH modular battery pack. It offers the best performance, incl. compressor operation. Depending on the intensity of use, the VUMAN can be operated 1 to 2 hours in battery mode. Seamlessly switch between charging, battery mode and mains. Due to its extensive intrinsic safety, fire hazard is minimized. Therefore, the VUMAN battery is approved for air transport.*



*Please beware the specific regulations of your country.



BASE UNIT	VUMAN® E3	VUMAN® E3 X-WAY	VUMAN® E3+	VUMAN® E3+ X-WAY
Dimensions in mm / inch	(W) 340 x (H) 420 x (D) 280 (W) 13.39 x (H) 16.54 x (D) 11.02	(W) 340 x (H) 420 x (D) 280 (W) 13.39 x (H) 16.54 x (D) 11.02	(W) 340 x (H) 420 x (D) 280 (W) 13.39 x (H) 16.54 x (D) 11.02	(W) 340 x (H) 420 x (D) 280 (W) 13.39 x (H) 16.54 x (D) 11.02
Weight	8.2 kg / 18.1 lbs	10 kg / 22 lbs	8.2 kg / 18.1 lbs	10 kg / 22 lbs (11.5 kg / 25.4 lbs)*
X-WAY drive	-	Integrated compressor, maintenance free.	-	Integrated compressor, maintenance free.
Probe length	max. 20 m / 65.6 ft.	max. 20 m / 65.6 ft.	max. 20 m / 65.6 ft.	max. 20 m / 65.6 ft. or 30 m* / 100 ft.
Construction	Aluminium-Carbon fiber with elastomer bumpers			
LED light source	Color temperature: 5.800 K, lifetime warranty			
System memory	10GB SSD	10GB SSD	80GB SSD	80GB SSD
VUSCREEN mount	✓	✓	✓	✓
VUSCREEN transport bracket	✓	✓	✓	✓
Connectors	USB 3.0, 12V (DC) / 750mA Out, optional external compressed air (X-WAY)			
Video input	-	-	PAL / NTSC, Composite, S-Video	PAL / NTSC, Composite, S-Video
Video output	HDMI	HDMI	HDMI, optionally with additional TV-Out (Composite, S-Video)	HDMI, optionally with additional TV-Out (Composite, S-Video)*
AC input	100V (AC) - 240V (AC), 50 Hz - 60 Hz, max. 240 Watt			
Environmental specifications	Operation: -10°C (+14°F) to +48°C (+118°F) Storage: -25°C (-13°F) to +65°C (+149°F) Relative humidity: max. 95 %, non-condensing			
Software Kit	E3		E3+	
Software	<ul style="list-style-type: none"> • Default user with English user interface • Probe articulation display (X-WAY) • Articulation mode: absolute • Dual LED illumination with boost • White balance • Text generator (Latin/Cyrillic) • File manager • Image freeze function • Image capture (JPG) • Video recording (AVI up to 60 s) • Integrated media player • Backup function 		Additional features of the E3+ <ul style="list-style-type: none"> • Individual user 1-9 and multilingual user interface • Absolute and relative articulation mode (with freeze function) • Individually controllable dual LED illumination with boost • Brightness, contrast, color saturation • Continuous shooting with varying illumination • Extended brightening features (time exposure) • Digital image processing (presets) • Mirror, zoom and rotate • Measurement function • Individual reference chart / customer logo • Image freeze with point marker • Audio comments • Unlimited video recording • Choose image and video format (JPEG, BMP, AVI, MPG) in three quality levels • Extended text generator (e. g. editable text blocks, text and background color) • Extended file manager • Documentation of external video sources 	

* The 30 m version of VUMAN® E3+ X-WAY is always fully equipped and comes with an extended probe deployment drum.





VUMAN® E3 PROBES	6 X-WAY	6	8 X-WAY	8	REVOLVER 12.7
Probe diameter in mm / inch	6.1 / 0.24	6.1 / 0.24	8.4 / 0.33	8.4 / 0.33	12.7 / 0.5
Probe length in m / ft.	5 / 16.4 8 / 26.3 12 / 39.4 15 / 49.3 20 / 65.6 30 / 100	8 / 26.3 15 / 49.3	5 / 16.4 8 / 26.3 12 / 39.4 15 / 49.3 20 / 65.6 30 / 100	8 / 26.3 15 / 49.3	8 / 26.3 15 / 49.3
X-WAY articulation left / right	up to max. 100°*	-	up to max. 140°*	-	-
X-WAY articulation up / down	up to max. 120°*	-	up to max. 160°*	-	-
Springloaded camera head	-	✓	-	✓	-
Remote Focus (RF)	✓	✓	✓	✓	-
Focus range	3 mm to ∞	3 mm to ∞	5 mm to ∞	5 mm to ∞	manual focus
Direction of view (DOV)	0°	0°	0°	0°	0° (360° rotating)
Field of view (FOV)	45°	45°	70°	70°	60°
Resolution	470.000 px	470.000 px	440.000 px	440.000 px	440.000 px
Mounting for centering device	✓	✓	✓	✓	✓
Mounting for side view adapter	✓	✓	✓	✓	✓
Material	Hard wearing tungsten braid on polyurethane probe		Ultra flexible stainless steel braid on polyurethane probe		
Waterproof up to 1.5 bar / 22 psi	✓	✓	✓	✓	splash waterproof
Temperature in operation	-10°C (+14°F) to +75°C (+167°F)	-10°C (+14°F) to +75°C (+167°F)	-10°C (+14°F) to +75°C (+167°F)	-10°C (+14°F) to +75°C (+167°F)	-10°C (+14°F) to +75°C (+167°F)
Storage temperature	-25°C (-13°F) to +65°C (+149°F)	-25°C (-13°F) to +65°C (+149°F)	-25°C (-13°F) to +65°C (+149°F)	-25°C (-13°F) to +65°C (+149°F)	-25°C (-13°F) to +65°C (+149°F)
Centering device kit included in scope of delivery	-	-	-	-	✓

*depending on the position of the probe





ACCESSORIES

<p>Transport case with wheels VUMAN® base unit</p>	<p>Dimensions in mm / inch: (W) 635 / 25 x (H) 510 / 20.08 x (D) 365 / 14.37</p> <p>Weight (empty): 8.7 kg / 19.1 lbs</p>	
<p>Transport case VUMAN® spare probe</p>	<p>Dimensions in mm / inch: (W) 415 / 16.34 x (H) 465 / 18.31 x (D) 190 / 7.48</p> <p>Weight (empty): 3.25 kg / 7.16 lbs</p>	
<p>Optional optic adapters</p>	<p>Side view prism for 6 mm interchangeable probes Side view prism with wide-angle for 6 mm interchangeable probes Wide-angle adapter for 6 mm interchangeable probes</p> <p>Side view prism for 8 mm interchangeable probes</p> <p>Side view mirror for 12.7 mm interchangeable probes</p>	
<p>Optional centering device kits</p>	<p>VUMAN® 6 mm X-WAY, Ø in mm / inch: 60 / 2.36 44 / 1.73 34 / 1.34 24 / 0.94 17 / 0.66</p> <p>VUMAN® 6 mm non-articulating, Ø in mm / inch: 44 / 1.73 19 / 0.74</p> <p>VUMAN® 8 mm X-WAY, Ø in mm / inch: 60 / 2.36 44 / 1.73 34 / 1.34 24 / 0.94 17 / 0.67</p> <p>VUMAN® 8 mm non-articulating, Ø in mm / inch: 60 / 2.36 44 / 1.73 34 / 1.34 24 / 0.94 17 / 0.67</p> <p>VUMAN® Revolver 12.7 mm, Ø in mm / inch: 60 / 2.36 46 / 1.81 36 / 1.42 26 / 1.02</p>	
<p>Optional pushing aid</p>	<p>PE coated glass fiber pushing aids with 4.5 mm / 0.17" for up to 30 m / 100 ft. video probe length</p>	
<p>Optional battery incl. charging unit</p>	<p>Capacity high-current NiMh battery: 11.000 mAh, 12 Volt</p> <p>Operation time: 1 - 2 h, X-WAY operation 5 % duty cycle</p>	

Are you missing the ideal VUMAN configuration for your individual application?
Contact us! viZaar is specialized in the development of customized special
solutions. We will gladly assist and advise you.



www.vizaar.com



FURTHER
INFORMATION

VUMAN[®] E3⁺

dition

EXPANDING YOUR VU[®]



viZaar industrial imaging AG
Headquarter
Hechinger Straße 152
72461 Albstadt / Germany
Tel.: +49 7432 98375-0
Fax: +49 7432 98375-50
Freecall 0800 3600371 (only within Germany)
info@vizaar.com

viZaar industrial imaging AG
VT Service / Rental Service / Sales / Training Center
Lupusstraße 17
35789 Weilmünster-Wolfenhausen / Germany
Tel.: +49 6475 91129-0
Fax: +49 6475 91129-29

OUR SALES AND SERVICE OFFICES

viZaar NRW
Sales and Service Office
46348 Raesfeld / Germany
Tel.: +49 170 5703130

viZaar North
Sales and Service Office
25361 Krempe / Germany
Tel.: +49 171 5524094

viZaar South
Sales and Service Office
88171 Weiler-Simmerberg / Germany
Tel.: +49 172 6019601



viZaar industrial imaging SA
3 rue Lambert
Parc Lavoisier
91410 Dourdan / France
Tel.: +33 1608 11818
Fax: +33 1645 99573
www.vizaar.fr
info@fort-fr.com

Authorised sales and service distributor of viZaar[®]:



viZaar Russia & CIS
197022, St. Petersburg / Russia
Professora Popova 37B
Tel. : +7 9852220677
www.vizaar.ru
info@vizaar.ru



viZaar South-East Asia Sdn. Bhd.
2A Lrg Desa Utama Jln Masjid Kayu
Ara PJU 6
47400 Petaling Jaya Selangor / Malaysia
Tel.: +603 772 217-10
Fax: +603 772 217-10
www.vizaarsea.com.my
info@vizaarsea.com.my